



prosper in a dynamic world

Revolver Contamination Design

Technical overview

Customer Name	DTN
DTN Reference	DTN-01
Revision	00
Revision Date	March 12 th 2025
Document Reference	Revolver

Revolver Disk System

The Revolver disk system is located in the front of the Revolver head of the transmitter, long receiver and the short receiver and is used to reduce the effect of contamination (dirt, dust etc) on the optical system.

The disk system is used in the contamination compensation operation which significantly extends the usable period for a window, and also changes the window when it becomes too contaminated for reliable measurements.

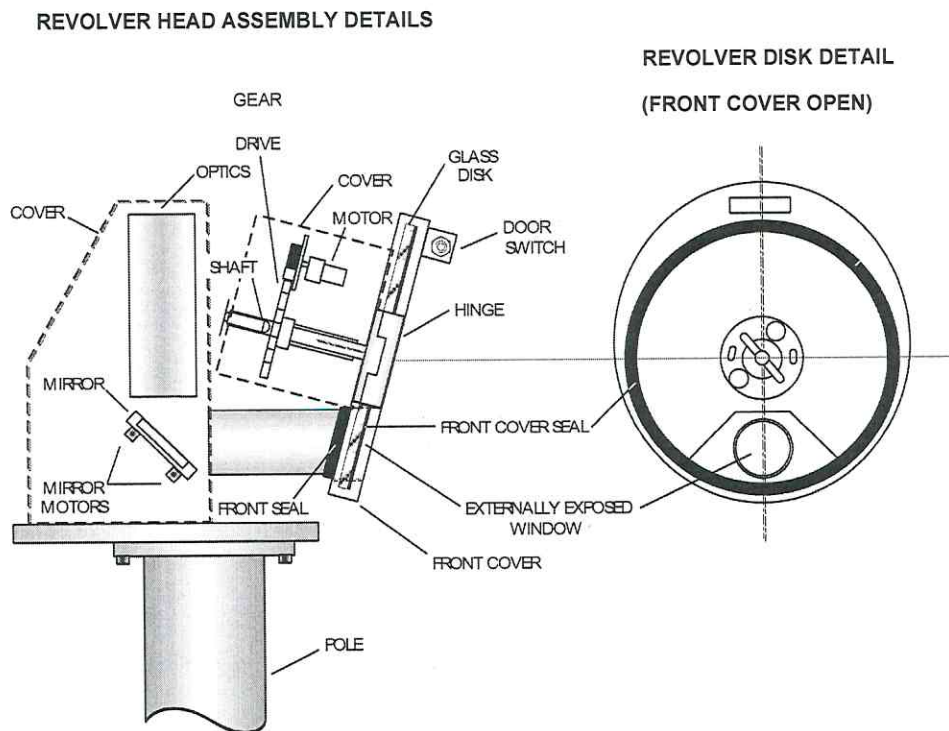

Figure 15: Revolver Disk Rotation – Hood Removed

The rotating disk is made from a single piece of glass, which is located in front of the transmitter and receiver optics. Only a small section of the disk is exposed to the outer environment at any time, and this is the section of disk that is used to transmit or receive light. The rest of the glass disk is sealed from the outer environment, so it stays clean until it is rotated into use at a later date. This disk gives the transmitter or receiver 6 window positions and the maintenance period of the DTN Revolver system is therefore five times longer than that of conventional contamination detection methods, **significantly reducing the ongoing operating cost of the system.**

By the way, replacing the disk is more convenient and gives better and safer results than cleaning windows on site. The disk can be cleaned in a workshop, rather than by a technician standing on a ladder, possibly in poor light.